

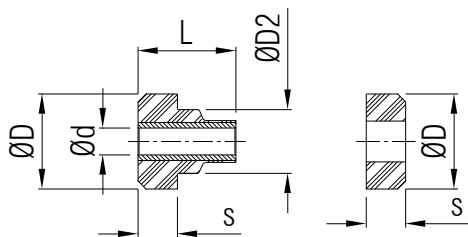

H Mountings

Standard parts are manufactured in chloroprene rubber and have resistance to oils and greases. Please see sketches below for typical captive installations. Please contact us for rubber hardnesses that are not shown on the stiffness graphs. Minimum order quantities may apply unless parts are available from stock.

Dimensions



Part No.	ØD (mm)	L (mm)	Ød (mm)	s (mm)	ØD2 (mm)
H-MTG1964	33.2	31.7	10.4	12.3	20.1
H-MTG2106	47.7	49.2	13.5	19.8	32.0
H-MTG1936	47.7	49.2	13.5	19.8	33.0
H-MTG1937	64.8	61.7	16.8	22.9	40.1
H-MTG2191	89.0	73.4	23.8	26.0	57.0

Example of Installation

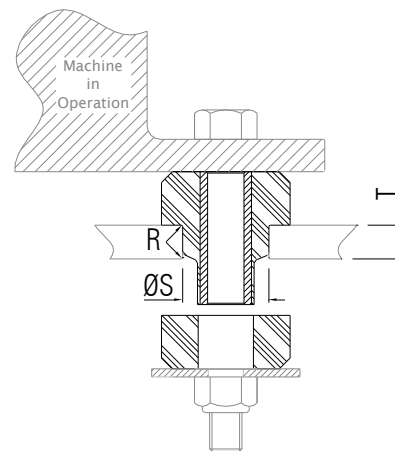
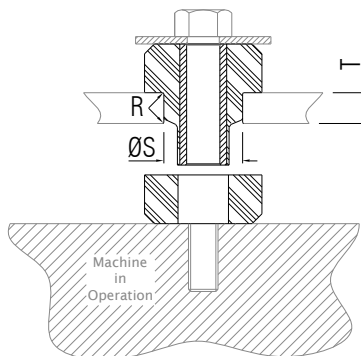
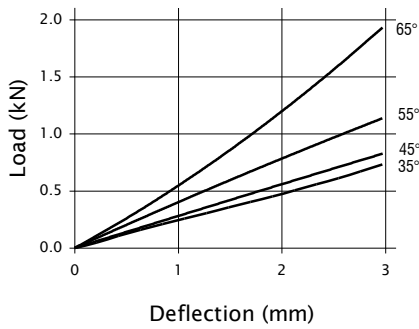

Table of Installation Dimensions

Part No.	ØS (Support Structure)	T (Support Structure)	R (Support Structure)
	(mm)	(mm)	(mm)
H-MTG1964	19.0	9.5	1.0
H-MTG2106	31.0	12.5-14.0	1.5
H-MTG1936	31.7	12.5-14.0	1.5
H-MTG1937	38.1	19.1-22.2	2.3

Compression Characteristics

H-MTG1964 - AXIAL



H-MTG2106 - AXIAL

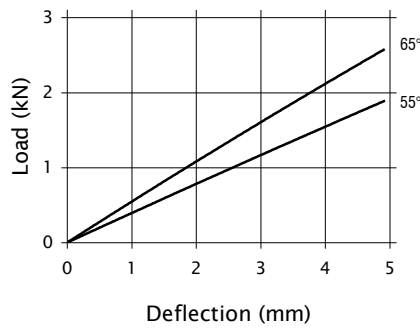

H-MTG1936 - AXIAL

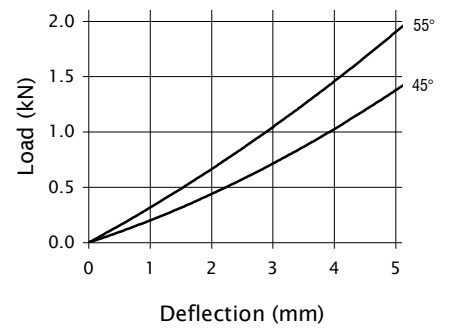

H-MTG1937 - AXIAL

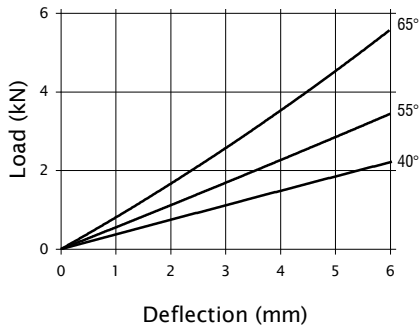

Note: There is a possible deviation of $\pm 20\%$ in the above load/deflection graphs due to production and hardness tolerances



T Mounts

Standard parts are manufactured in chloroprene rubber or natural rubber. Minimum order quantities may apply unless parts are available from stock.

Dimensions

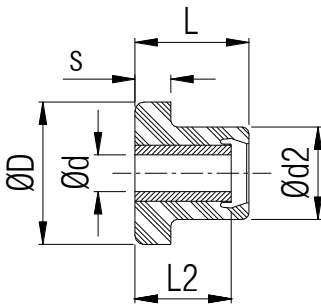

Part No.	Ød (mm)	ØD (mm)	L (mm)	Ød2 (mm)	L2 (mm)	s (mm)
T-MTG1676	10.16	27.69	26.17	20.45	15.88	6.35
T-MTG1674	10.22	25.91	13.97	19.43	11.56	5.08
T-MTG1679	13.00	44.45	31.75	31.50	25.40	9.65
T-MTG1682	13.21	50.80	41.66	34.04	33.27	13.72
T-MTG1691	16.26	63.50	30.23	38.10	23.88	15.75
T-MTG1697	16.34	75.31	56.39	50.04	50.80	20.58
T-MTG1685	17.02	50.80	31.75	34.30	25.40	13.46
T-MTG1708	20.40	95.25	63.50	56.64	50.80	25.40

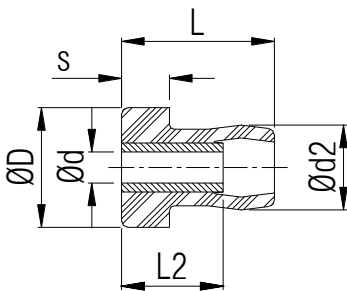

Part No.	Ød (mm)	ØD (mm)	L (mm)	Ød2 (mm)	L2 (mm)	s (mm)
T-MTG1692	16.51	63.50	81.0	40.64	53.85	25.40

Example of Installation

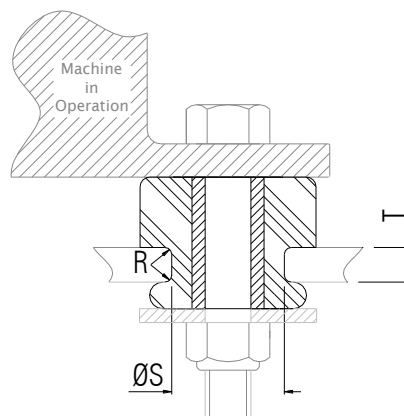

Table of Installation Dimensions

Part No.	ØS (Support Structure)	T (Support Structure)	R (Support Structure)
	(mm)	(mm)	(mm)
T-MTG1676	18.80	7.87	1.0
T-MTG1674	19.05	3.43	1.0
T-MTG1679	28.45	9.65	1.5
T-MTG1682	31.75	15.75	-
T-MTG1691	-	-	-
T-MTG1692	38.10	19.05	-
T-MTG1697	45.97	23.62	-
T-MTG1685	31.75	6.35	-
T-MTG1708	50.8	19.05	-